

DRIVER, TRACK AND RESULTS

| | | | | | | | |
|---------------------|---|------------------|---|-------------------|---|----------------------|--|
| DRIVER | Stuart Rand | COUNTRY | UK | WEATHER | AIR TEMP 15c | TRACK TEMP 10c | <input type="checkbox"/> DRY <input checked="" type="checkbox"/> INTERMEDIATE <input type="checkbox"/> WET |
| RACE | Maritime Astro wars rd5 | DATE | February | QUALY POS. | 3 | STARTING POS. | FINAL POS. |
| TRACK | Maritime Raceway | TYPE | <input checked="" type="checkbox"/> INDOOR <input type="checkbox"/> OUTDOOR | STYLE | <input type="checkbox"/> TIGHT <input checked="" type="checkbox"/> MEDIUM <input type="checkbox"/> OPEN | | |
| SURFACE GRIP | <input type="checkbox"/> LOW <input type="checkbox"/> MEDIUM <input checked="" type="checkbox"/> HIGH | CONDITION | <input checked="" type="checkbox"/> SMOOTH <input type="checkbox"/> ROUGH | | | | |
| TYPE | <input type="checkbox"/> HARD PACKED <input type="checkbox"/> CLAY <input type="checkbox"/> CARPET <input type="checkbox"/> MULTI/SURFACE <input type="checkbox"/> GRASS <input type="checkbox"/> BLUE GROOVE <input type="checkbox"/> DIRT <input type="checkbox"/> ASTRO-TURF <input checked="" type="checkbox"/> High Grip | | | | | | |

| FRONT | SHOCK ABSORBERS | REAR |
|--|-----------------|---|
| AE 37.5 cst | OIL | AE 30 cst |
| AE RED | SPRINGS | AE WHITE |
| 0 mm | REBOUND | 0 mm |
| 21mm long ball end mm | LIMITERS | 29mm long ball end mm |
| N° HOLES 2 | Ø 1.6 mm | PISTONS N° HOLES 2 |
| Ø 1.7 mm | PISTONS TYPE | <input type="checkbox"/> STOCK <input type="checkbox"/> CONICAL <input type="checkbox"/> SQUARE |
| <input type="checkbox"/> SHORT <input type="checkbox"/> LONG | SPRING BUCKETS | <input type="checkbox"/> SHORT <input type="checkbox"/> LONG |
| <input type="checkbox"/> BLADDER | SEAL | <input type="checkbox"/> BLADDER |
| <input checked="" type="checkbox"/> EMULSION | TYPE | <input checked="" type="checkbox"/> EMULSION |

| FRONT | ANTI-ROLL BARS | REAR |
|--------------------------|--------------------------------|--------------------------|
| <input type="checkbox"/> | <input type="checkbox"/> OTHER | <input type="checkbox"/> |
| 0.9 | 1 | 1.1 |
| | mm | |
| | 1.1 | 1.3 |
| | 1.5 | |
| | mm | |

| REAR DIFFERENTIAL | |
|--|---|
| <input type="checkbox"/> BALL DIFFERENTIAL | DIFFERENTIAL HEIGHT |
| <input checked="" type="checkbox"/> GEAR DIFF AE 15000 cst | <input checked="" type="checkbox"/> HIGH <input type="checkbox"/> MED <input type="checkbox"/> LOW <input type="checkbox"/> FIXED |

| GEARING | |
|-----------|----------|
| PINION | 23 Teeth |
| SPUR GEAR | 82 Teeth |

| ELECTRONICS | |
|-------------|----------|
| BATTERY | |
| BRAND | REEDY |
| CAPACITY | 5300 mAh |
| MOTOR | |
| BRAND | GFORCE |
| TYPE | 7.5 |
| TIMING | 40deg |
| ESC | |
| BRAND | ORION |
| TYPE | R10 |

| AERODYNAMIC CONFIGURATION | |
|---------------------------|--|
| BODY BRAND | Kit |
| TYPE | Kit |
| REAR WING BRAND | Proline |
| TYPE | |
| REAR WING WIDTH | 7.5 |
| REAR WING LIP | mm |
| REAR WING ANGLE | <input checked="" type="checkbox"/> 0° <input type="checkbox"/> 2° <input type="checkbox"/> 4° <input type="checkbox"/> 6° <input type="checkbox"/> 8° |
| FRONT WING | <input type="checkbox"/> YES <input checked="" type="checkbox"/> NO |
| TYPE | |

| FRONT | TIRES | Controlled Tire | REAR |
|----------------------|----------|--------------------------|------------|
| Schumacher | MAKE | <input type="checkbox"/> | Schumacher |
| Cut Stagger | TYPE | <input type="checkbox"/> | Mini Spike |
| Yellow | COMPOUND | <input type="checkbox"/> | Yellow |
| none | INSERTS | <input type="checkbox"/> | Pre glue |
| STD (inside rim cut) | WHEELS | <input type="checkbox"/> | STD |
| None | ADDITIVE | <input type="checkbox"/> | None |

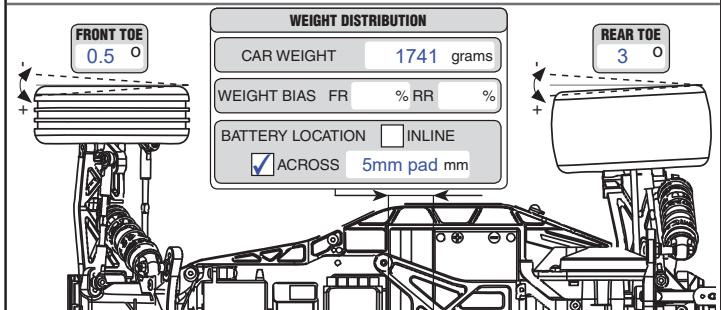
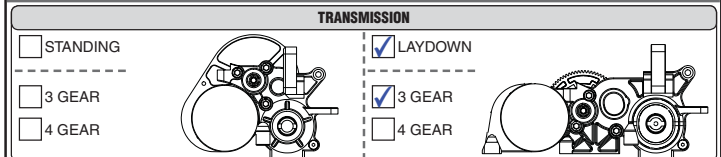
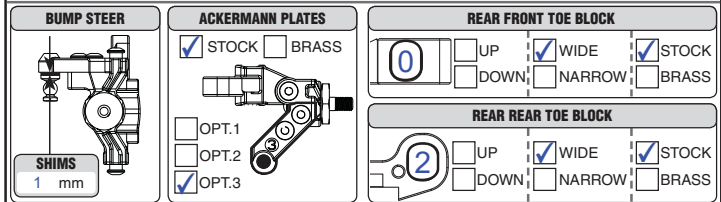
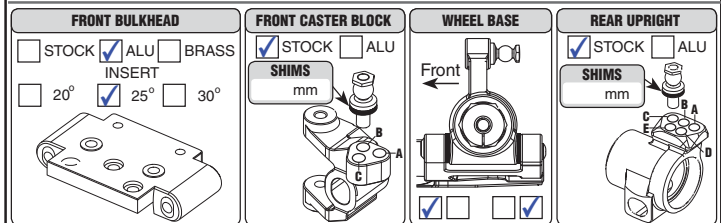
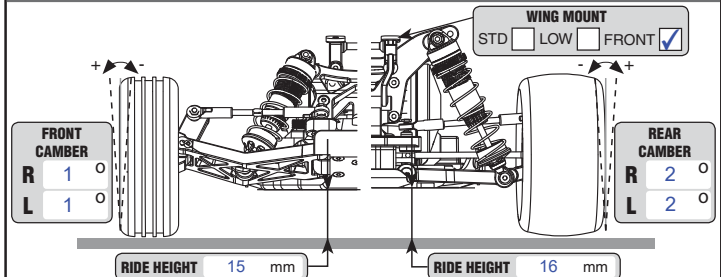
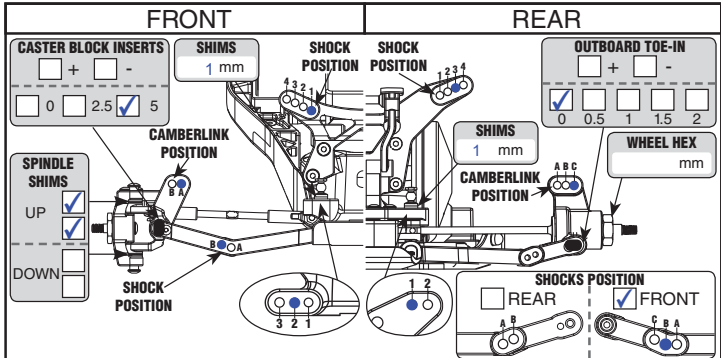

REMARKS

C-hub 500316 - Steering Block 500317 from SC
 1741 overall weight 2mm lead plate under Lipo/esc/servo (150g)
 Sc caster blocks and hubs (the car was very fast) Also lipos are in the forward position